



ILC DOVER
creating what's next



DRUM TIPPER

DRUM HANDLING

What is a Drum tipper?

The JetSolutions Drum Tipper provide a solution to move, lift and swing a drum in a horizontal position in a safe way

How it works

The drum can be loaded on the drum tipper from the floor. One adjustable belt in stainless steel secures the drum on the stainless steel cradle. A pneumatic drive swings the drum in horizontal position in order to be connected to the next step of the process.



Features & Benefits

- ✓ Safe handling of heavy drums
- ✓ Available in mobile or fixed design
- ✓ Powered with air pressure
- ✓ Available in ATEX execution

Application

- ✓ Lifting a drum or a box in a horizontal position
- ✓ Bringing a drum or a box for a connection to a flexible or rigid enclosure
- ✓ Emptying a drum or a box in a hopper

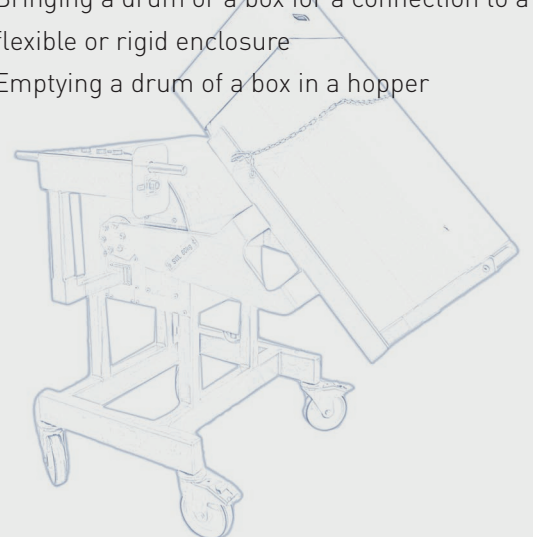

MOBILE DRUM TIPPER IN OPERATION

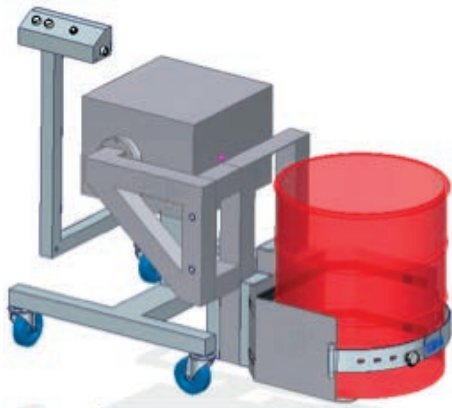

Drum loading

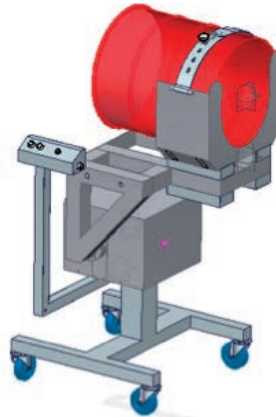

In Horizontal position

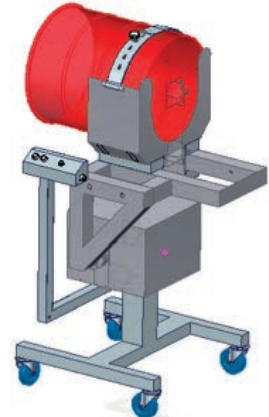

In forward position

AVAILABLE DIMENSIONS

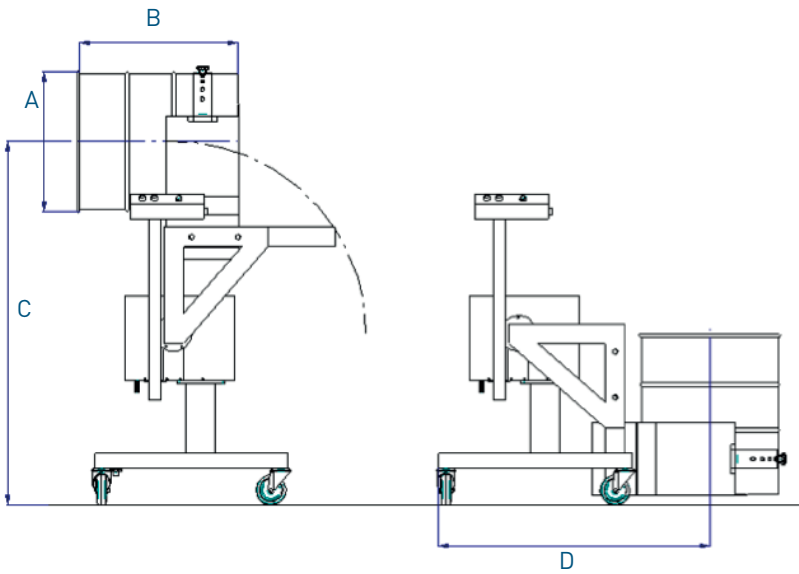

	Drum size	
A	340→550mm	Diameter
B	400→1000mm	Length
	Drum size	
C	~1500mm	Swinging height
D	~1150mm	Drum position in loading state

INSTALLING A BOX FROM THE FLOOR



DRUM TIPPER INTEGRATED IN A PROCESS EQUIPMENT

